



POS350

Robust and versatile point of sale for retail and hospitality applications



The POS350 is designed with the needs of both retail and hospitality point of sale applications in mind. Its durable aluminium chassis and water resistant construction combine to deliver an outstandingly versatile POS system with appealing aesthetics.

Bringing together Intel's efficient J1900 or i5-6200U processors with a bright 15.1" P-CAP touch screen, the POS350 delivers a highly responsive user experience. The POS350 also offers broad peripheral connectivity, including Powered Serial & USB, Cash Drawer, LAN and VGA ports. In addition, integrated peripheral options include MSR, iButton and Fingerprint Reader functionality.

The ability to communicate visually impactful promotions, offers and special events to customers is enabled by two specifically designed secondary screen options. Both the 8.4" and 10.1" high clarity, bright displays are designed to seamlessly mount onto the main unit and maintain its elegant aesthetics. The touch screen options for the secondary displays allow for customer interaction to drive customer engagement and feedback during a transaction.

In addition, the POS350 incorporates a number of additional protective features for added resilience in demanding environments. Aside from the water-resistant screen and chassis, built-in drainage points, an optional I/O ports splash guard and a counter-mount kit add further protection from liquid ingress.

The POS350 supports broad software compatibility for POS applications running on Windows 7, Windows Embedded POSReady 7, Windows Embedded 8.1 Industry Pro, Windows 10 IoT Enterprise LTSB and Linux Kernel 3.8 or above.

Features

- Water resistant screen and chassis
- Multiple integrated secondary display options
- Comprehensive I/O connectivity
- PSU embedded in stand
- Optional Counter-mount kit
- Optional I/O Ports splash guard
- Built-in drainage points
- MSR, iButton & Fingerprint integrated peripheral options

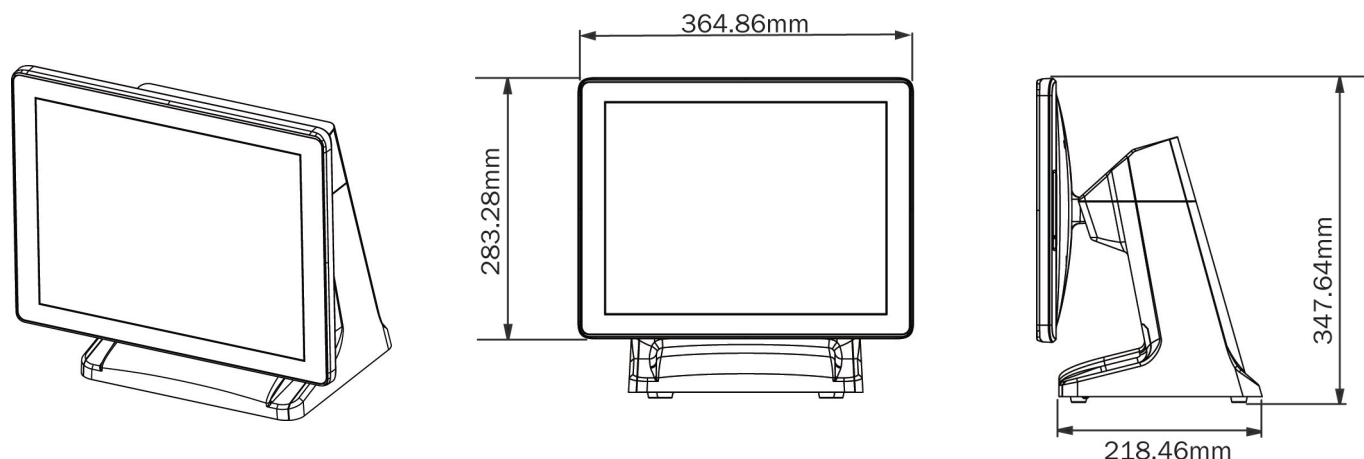

POS350	D36	D86U
Processor	Intel® Celeron® Processor J1900 2GHz Quad Core (turbo 2.4GHz) (fanless)	Intel® Core™ i5-6200U Skylake 2.3GHz Dual Core (turbo 2.8GHz) (fanless)
Storage	128GB SSD (1 x 2.5" SATA HDD or SSD), Optional M.2 Storage Device	
RAM	4GB (8GB max)	
Display	15.1" TFT-LCD / 1024 x 768 resolution	
Touch	P-CAP or Resistive touch	
Speaker	1 x 2W	
Brightness	250 nits	
Chassis	Aluminium	
Serial Port	3 x RJ45 COM (COM1 & COM2 with 5V, COM 3 with 12V, BIOS Selectable)	
USB Port	5 x USB (4 x USB 2.0 and 1 x USB 3.0)	6 x USB (4 x USB 3.0 and 2 x USB 2.0)
Powered USB Port	2 x Powered USB ports (1 x 12V, 1 x 24V)	
Cash Drawer Port	1 x RJ11 (12V / 24V BIOS selectable)	
LAN Port	1 x RJ45 Gigabit LAN	
Video Port	1 x VGA, 12V BIOS selectable	
Integrated Peripherals (optional)	3 Track MSR, Fingerprint Reader, iButton – attachable to either side of the system	
Secondary Displays (optional)	1 0.1" (800 x 1280) P-CAP touch, 8.4" (800 x 600) non-touch or LCM 2 x 20 customer display	
Additional Options	I/O splash guard & counter-mount kit	
EMC & Safety	FCC / CE Class A, LVD	
Wireless LAN	Optional 802.11 b/g/n Wireless LAN card & antenna	
Operating System	Windows 7 Windows Embedded POSReady 7 Windows Embedded 8.1 Industry Pro Windows 10 IoT Enterprise LTSC Linux Kernel 3.8 or above	Windows 7 Windows Embedded POSReady 7 Windows Embedded 8.1 Industry Pro Windows 10 IoT Enterprise LTSC Linux Kernel 4.3 or above

Intel Celeron J1900

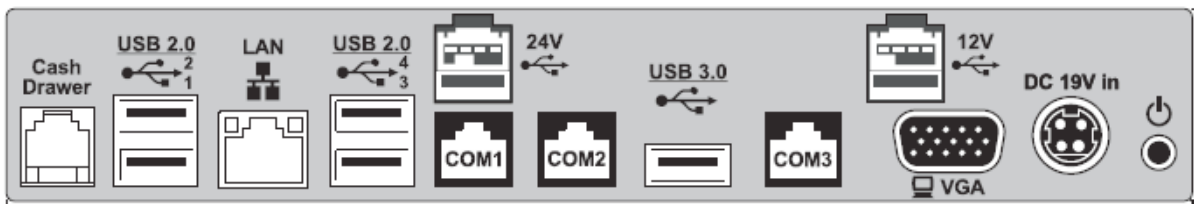

Intel i5-6200U

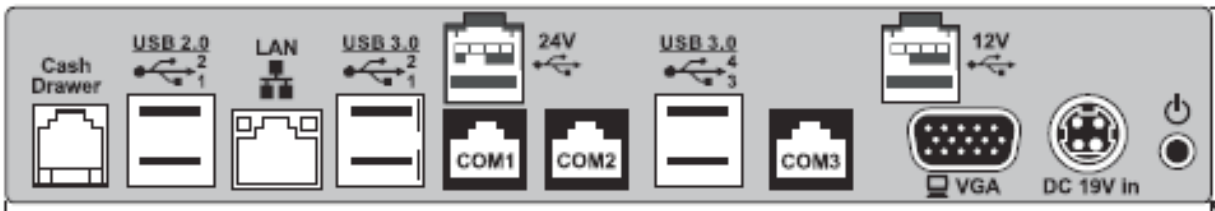

Optional Customer Screen



8" Customer Screen



10.1" Customer Screen



LCM Customer Screen



10.1" Customer Screen

